

LOUDOUN WATER

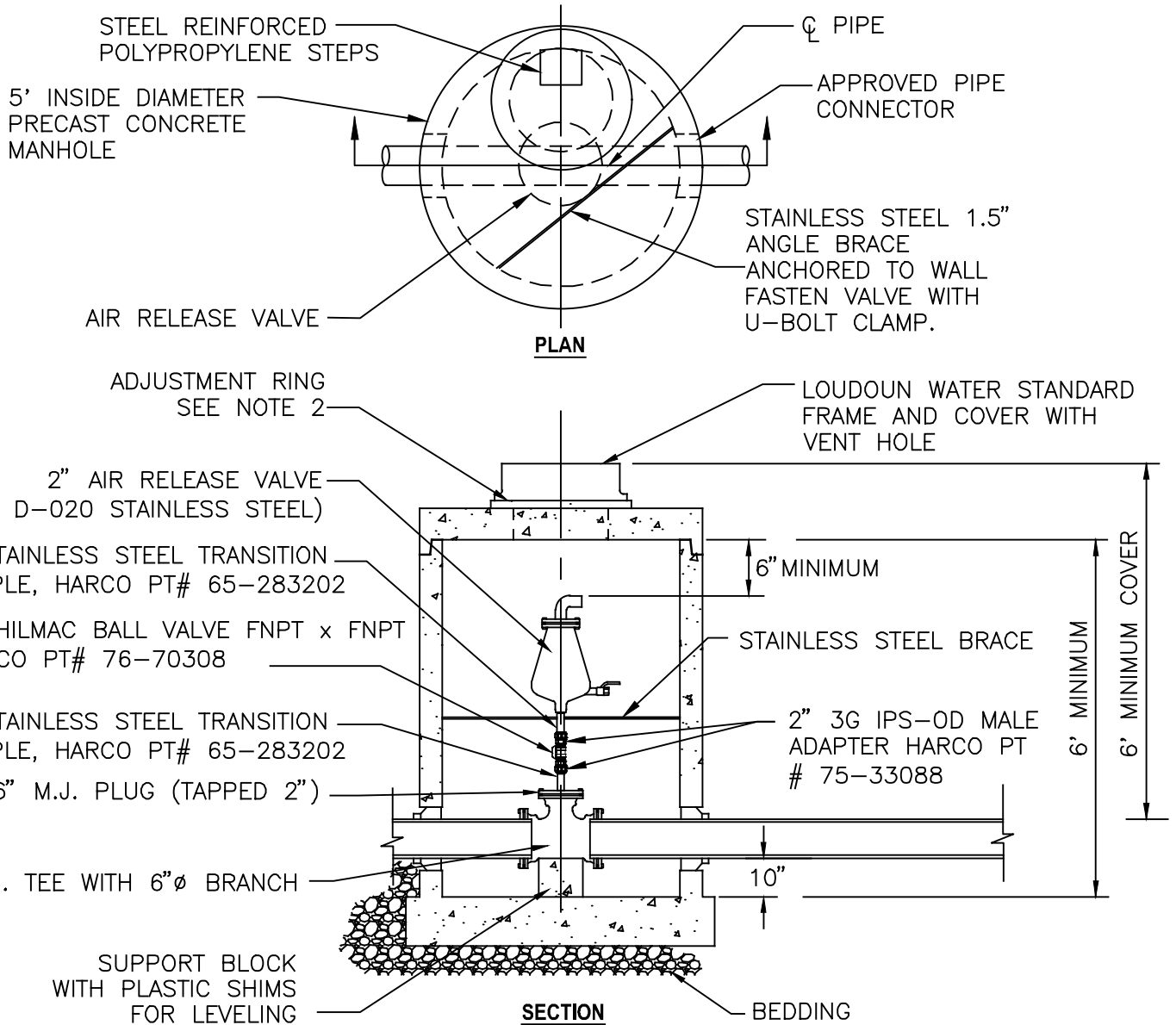

NOTES:

1. CONFINED SPACE: ATMOSPHERE MUST BE VENTED AND TESTED PRIOR TO ENTRY.
2. MAXIMUM ADJUSTMENT BY GRADE RINGS IS 12" IN PAVEMENT AND 6" ELSEWHERE.
3. MANHOLE SHALL BE REINFORCED TO MEET ASTM 478/AASHTO M199. JOINTS TO BE GASKETED IN ACCORDANCE WITH ASTM C443. APPLY PROPER LUBRICANT FOR ASSEMBLY.
4. ALL COMPONENTS TO BE IN ACCORDANCE WITH LOUDOUN WATER'S APPROVED MATERIALS LIST.
5. IF OUTSIDE PAVEMENT BOLT FRAME TO CONE.

AUG.
2018

FORCE MAIN AIR RELEASE

FM-1